



Home Learning Grid Year 1



Week Commencing – 29.06.20

Work to be completed in home learning books

1		2	3	4
English	1	2	3	4
English	1	2	3	4
English	1	2	3	4
English	1	2	3	4
English	1	2	3	4
English	1	2	3	4
English	1	2	3	4
English	1	2	3	4
English	1	2	3	4
English	1	2	3	4
English	1	2	3	4
English	1	2	3	4
English	1	2	3	4
English	1	2	3	4
English	1	2	3	4
English	1	2	3	4
English	1	2	3	4
English	1	2	3	4
English	1	2	3	4
English	1	2	3	4
English	1	2	3	4
English	1	2	3	4
English	1	2	3	4
English	1	2	3	4
English	1	2	3	4
English	1	2	3	4
English	1	2	3	4
English	1	2	3	4
English	1	2	3	4
English	1	2	3	4
English	1	2	3	4
English	1	2	3	4
English	1	2	3	4
English	1	2	3	4
English	1	2	3	4
English	1	2	3	4
English	1	2	3	4
English	1	2	3	4
English	1	2	3	4
English	1	2	3	4
English	1	2	3	4
English	1	2	3	4
English	1	2	3	4
English	1	2	3	4
English	1	2	3	4
English	1	2	3	4
English	1	2	3	4
English	1	2	3	4
English	1	2	3	4
English	1	2	3	4
English	1	2	3	4
English	1	2	3	4
English	1	2	3	4
English	1	2	3	4
English	1	2	3	4
English	1	2	3	4
English	1	2	3	4
English	1	2	3	4
English	1	2	3	4
English	1	2	3	4
English	1	2	3	4
English	1	2	3	4
English	1	2	3	4
English	1	2	3	4
English	1	2	3	4
English	1	2	3	4
English	1	2	3	4
English	1	2	3	4
English	1	2		

Maths	Summer Term Week 10 Lesson 1 – ordering numbers	Summer Term Week 10 Lesson 2 – recognising coins	Summer Term Week 10 Lesson 3 – recognising notes	Summer Term Week 10 Lesson 4 – counting in coins
	See sheet attached below. Video link – https://whiterosemaths.com/home/learning/year-1/	See sheet attached below. Video link – https://whiterosemaths.com/home/learning/year-1/	See sheet attached below. Video link – https://whiterosemaths.com/home/learning/year-1/	See sheet attached below. Video link – https://whiterosemaths.com/home/learning/year-1/
Outdoors	The Big Den Challenge			
	<p>Let's Make a Den!!!</p> <p>Whether it's inside or outside, let's try to make a den. Your very own place to relax, paint, work, sleep, read – whatever you want. See below for help.</p>	<p>Home Scavenger Hunt</p> <p>Use your den as a base to collect as many of things as you can from our home scavenger hunt.</p>	<p>Be the King or Queen</p> <p>You have a den? Check. Now you are the king or queen of the castle, you'll need a crown too. Read below.</p>	<p>Relax and Read in Your Kingdom</p> <p>Send us a photo, on Seesaw, of you reading a good book in your den.</p>
PE	School Games Active Championships 			

As you are aware, the Oak National Academy also provide a wealth of learning opportunities during the national lockdown. These can be assessed here: <https://www.thenational.academy/online-classroom> . We understand that some families may prefer to work from these materials and this is absolutely fine. Our new grids will hopefully encourage children to use the final few weeks of term to get outdoors where possible and be creative. We are thrilled to see so many children learning at home and taking the opportunity to also do all kinds of things at home which are not usually taught in the classroom. We would like to sincerely thank everyone for their support during this strange time.



Inventing My Own Character

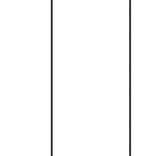
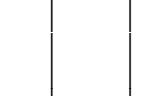
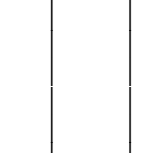
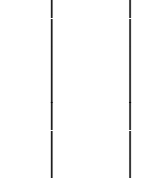
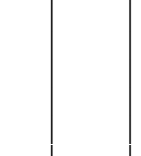
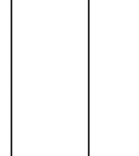
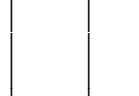
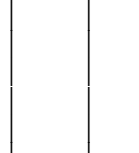
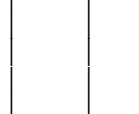
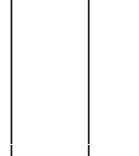
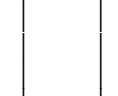
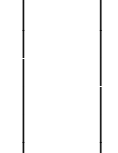
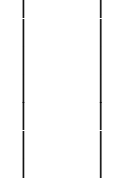
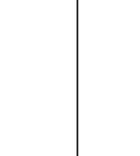
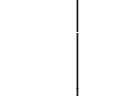
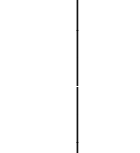
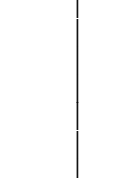
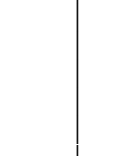
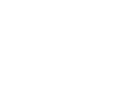

Story Map

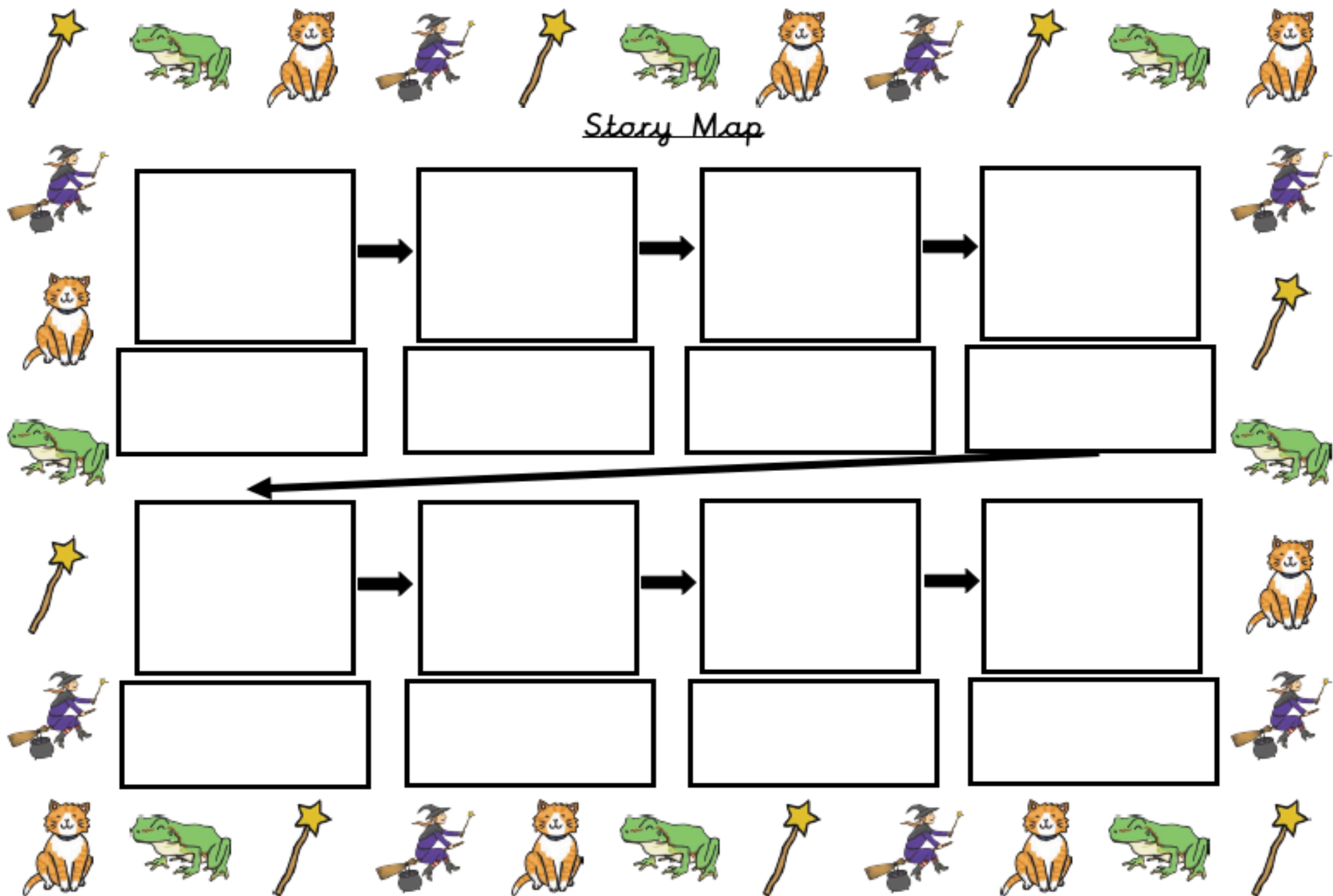



Story Map



NCO:

- To retell familiar key stories that I have read.
- To say out loud what I am going to write about, composing sentences orally before writing them.
- To write a story with a beginning, middle and end.



Blank writing box with horizontal lines.



Blank writing box with horizontal lines.



Blank writing box with horizontal lines.



Blank writing box with horizontal lines.



Blank writing box with horizontal lines.



Blank writing box with horizontal lines.





A large rectangular writing area with a black border, containing ten horizontal lines for text entry.

A second large rectangular writing area, identical to the first, with a black border and ten horizontal lines.





Invent a Flying Broomstick Worksheet

Can you design your own special broomstick?

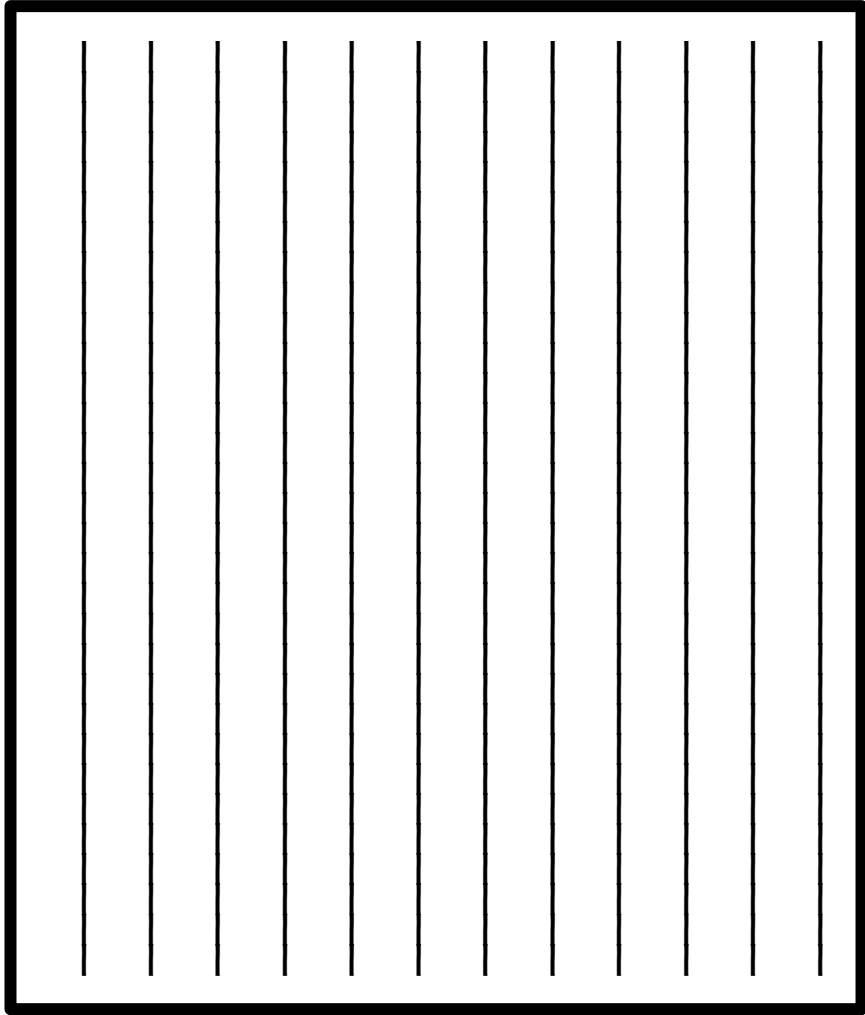

Ordering numbers

1 a) What numbers are shown?

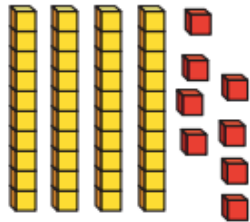

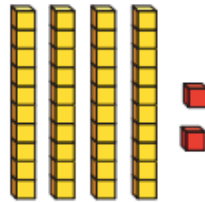

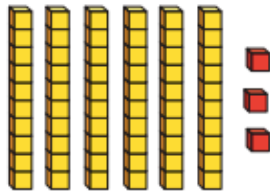

b) Write the numbers in order. Start with the smallest.

smallest

greatest

2 Three hens lay these eggs.

Hen 1	Hen 2	Hen 3

Put the number of eggs in order. Start with the greatest number.

greatest

smallest

- 3 Three numbers are labelled on a number line.

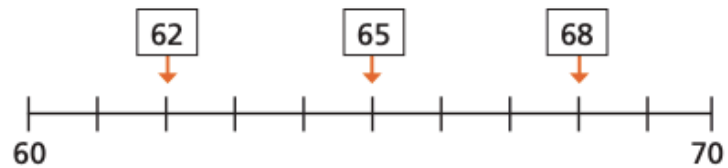

Write the numbers in order.
Start with the smallest number.

smallest

greatest

- 4 Put the numbers in order.
Start with the smallest number.

a) 53, 58, 47

b) 19, 83, 7

- 5 Tick all the numbers between 80 and 100

72 95 11 85 9

Recognising coins

1 Match the coin to the amount.



20 pence



5 pence



10 pence



1 pound



1 pence



50 pence



2 pence



2 pounds



2 Here are some coins.



Complete the sentences.

There are 1p coins.

There are 2p coins.

There is 5p coin.

There are 10p coins.

There are 20p coins.

3 Write < or > to compare the amounts.





4 Mo has one coin in his hand.



I have more than 2 pence,
but less than 1 pound.

Draw Mo's coin.



What is the value of Mo's coin?

 p

Is there more than one answer?



Recognising notes



1 Match the note to its value.



5 pounds



20 pounds



10 pounds



50 pounds

2 Dan has two £10 notes and one £5 note.

Circle the notes that Dan has.

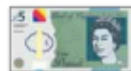

3 Here are some notes.



Complete the sentences.

There are £5 notes.

There are £10 notes.

There are £20 notes.

There are £50 notes.

4 Tick the note with the smaller value.

a)



b)

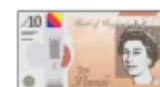

c)

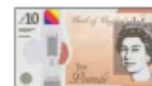

5 Write $<$, $>$ or $=$ to compare the amounts.

a)  50 pounds

b) 20 pounds 

c)  10 pounds

6 Kim has some money.



I have a 30 pound note.

Do you agree with Kim? _____

Talk about your answer.



Counting in coins

1 How much money is there?



a)

<input type="text"/> p	<input type="text"/> p	<input type="text"/> p	<input type="text"/> p

b)

<input type="text"/> p	<input type="text"/> p	<input type="text"/> p	<input type="text"/> p

c)

<input type="text"/> p	<input type="text"/> p	<input type="text"/> p	<input type="text"/> p

d)

<input type="text"/> p	<input type="text"/> p	<input type="text"/> p	<input type="text"/> p

2 How much money is there?



a)

	<input type="text"/> p
--	------------------------

b)

	<input type="text"/> p
--	------------------------

c)

	<input type="text"/> p
--	------------------------

3 Write <, > or = to compare the amounts.



a)

	<input type="text"/>	
--	----------------------	--

b)

	<input type="text"/>	
--	----------------------	--





4 Sam has some 2p coins.



I have 11 pence.

Do you agree with Sam? _____

Talk about your answer.

5 Ron has nine 2p coins.

Jo has three silver coins.



I must have more money because I have more coins.

Ron

Do you agree with Ron? _____

Talk about your answer.





VICTORIA DOCK PRIMARY SCHOOL'S

BIG DEN CHALLENGE

Have a go at making your own den at home. Whether it is indoor or outdoor, use whatever you have around the house (and some adult supervision) to create your own place to relax, paint, work, sleep, read - whatever you want. See below for help and look out for some special certificates towards the end of the week

Outdoor – Den Building

This week's challenges all revolve around making some kind of den. This can be inside or outside. (We can never predict the weather.) Here are some different instructions for making a den at home. Be as creative as you'd like.

This family furniture website has lots of different ideas for making your own den. I particularly love the fairy light idea. Visit <https://www.noaandnani.co.uk/den-building-ideas-for-the-best-dens-ever-i43> for more but below are some things to get you started.

Stuff for the Structure

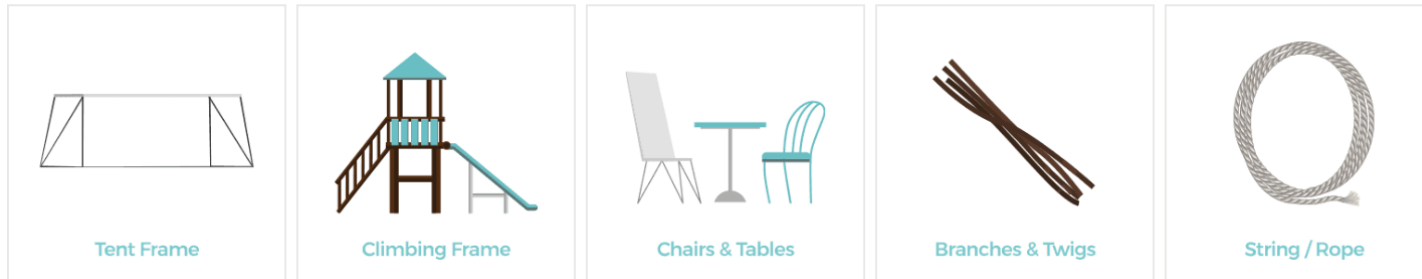

Shelter & Extras



You'll need something to make your den comfy and cosy!

Use battery or solar lights to decorate

Sweets, popcorn, games and books add fun!

1. Use Ready-Made Structures

If you have family tents or if you have a climbing frame in your back garden, these make excellent ready-made structures to form the basis of your den. You can drape your sheets or tarpaulins over the top and add other structures onto the sides to make giant mansion dens (if you're feeling ambitious).

2. Garden Furniture Fortress

If you're struggling for a structure, garden furniture makes the perfect solution. If you have 4 or 6 garden chairs, try arranging them back-to-back with space in the middle. This provides a support structure for you to drape a sheet or tarpaulin over the top, creating an instant den. Garden tables also make the perfect starter structure; simply drape over a sheet and you've got a cosy hiding place with a ready-made roof.

3. Building with Branches

If you're lucky enough to live near woodland, you can go foraging for fallen branches and twigs to use as your outdoor den structure. Make sure these really are already on the ground, and don't be tempted to remove them from their trees yourself. Your den should not harm the natural world around you. The bigger branches can be leaned up against one another and tied to form a basic den structure, while smaller bendy twigs can be woven between to fill in the walls.

4. Waterproofing

The most challenging element of building outdoor dens is making sure they are waterproof, just in case the heavens open. With any luck you'll get a nice sunny, dry day, but it pays to be prepared. The best things to use for waterproofing your outdoor den are plastic sheets and tarpaulins, as these are completely waterproof and very easy to work with. Or, if you want your den to be completely natural, you can use leaves. The bigger and broader the leaves the better, but make sure these are already on the ground and you're not taking them off living trees. You'll also need lots and lots to make sure your den doesn't leak; try layering up leafy branches and twigs to fill the gaps.

5. Painting Personalisation

If you've created your den walls using cardboard or branches, why not give them a lick of paint to create a colourful, personalised look? You can paint your branches in all kinds of colours or paint yourself your very own front door and some windows if you're using cardboard walls. Just make sure you only do this on a dry day and don't paint anything important like your garden furniture or climbing frames!

6. Something to Sit On

An upturned box or crate makes a surprisingly good seat or table for a little den, especially with an additional cushion or two. Spare pieces of cardboard also make excellent den flooring, providing a thick, clean and surprisingly comfortable layer of protection between you and the ground.





7. Light it Up

To make your outside den prettier and more practical in the dark, try adding battery or solar-powered fairy lights. You can dangle them from the roof of your structure or drape them over the top, or you can lay them out on the ground inside your den for a magical glow.

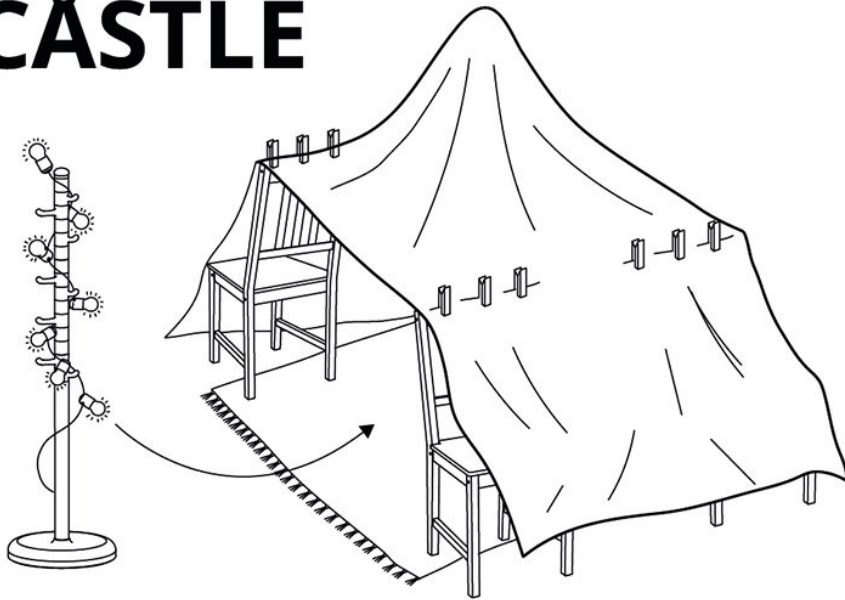
Alternatively, what about these guides from the popular shop, IKEA?

CÅSTLE

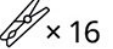
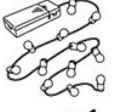
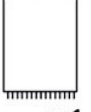



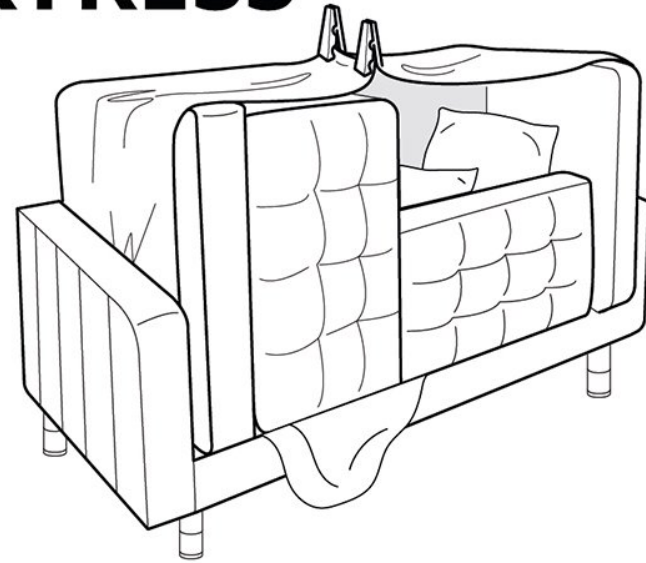

STEFAN  × 4	KROKIG  × 1	NATTJASMIN  × 2  × 16	BLÖTSNÖ  × 1	TAULOV  × 1	VALBJÖRG  × 3
---	---	---	--	---	---

Make sure that the structure is safe. Do not leave children unattended.
The suggested examples are not official IKEA user guides for IKEA products.
If you can't find the products referred to in the instructions, use similar ones.

FÖRTRESS



LANDSKRONA  × 1	NATTJASMIN  × 2  × 10	MIALOTTA  × 1	VALBJÖRG  × 3
---	--	---	---

Make sure that the structure is safe. Do not leave children unattended.
The suggested examples are not official IKEA user guides for IKEA products.
If you can't find the products referred to in the instructions, use similar ones.

WIGWÅM

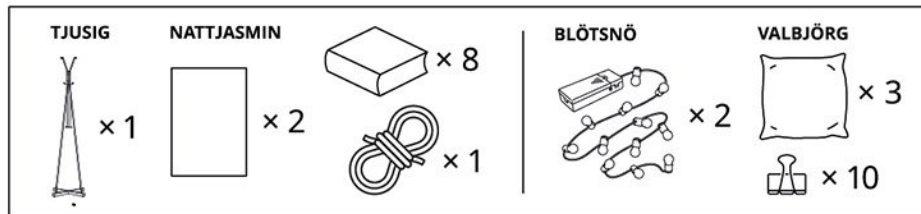
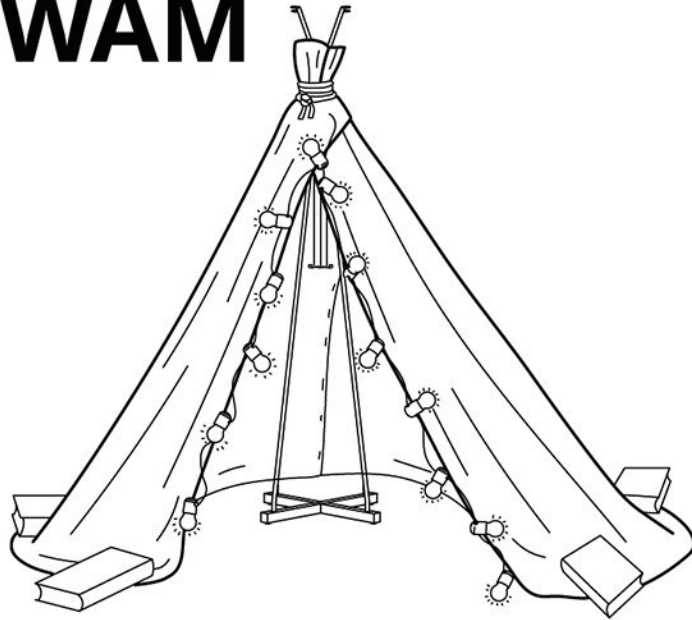

Make sure that the structure is safe. Do not leave children unattended.
The suggested examples are not official IKEA user guides for IKEA products.
If you can't find the products referred to in the instructions, use similar ones.

HÖUSE

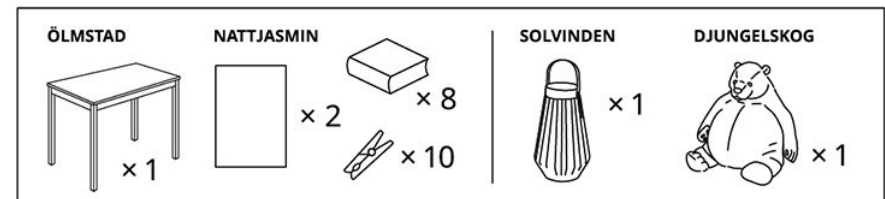

Make sure that the structure is safe. Do not leave children unattended.
The suggested examples are not official IKEA user guides for IKEA products.
If you can't find the products referred to in the instructions, use similar ones.

CÅMPINGTENT

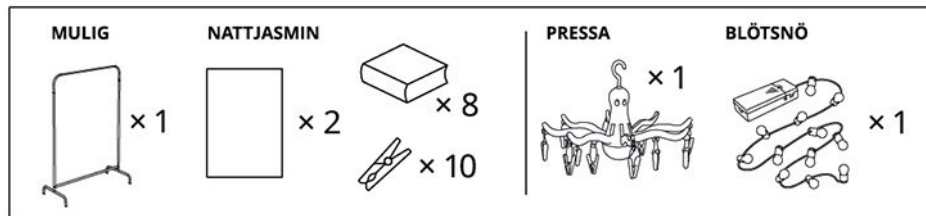
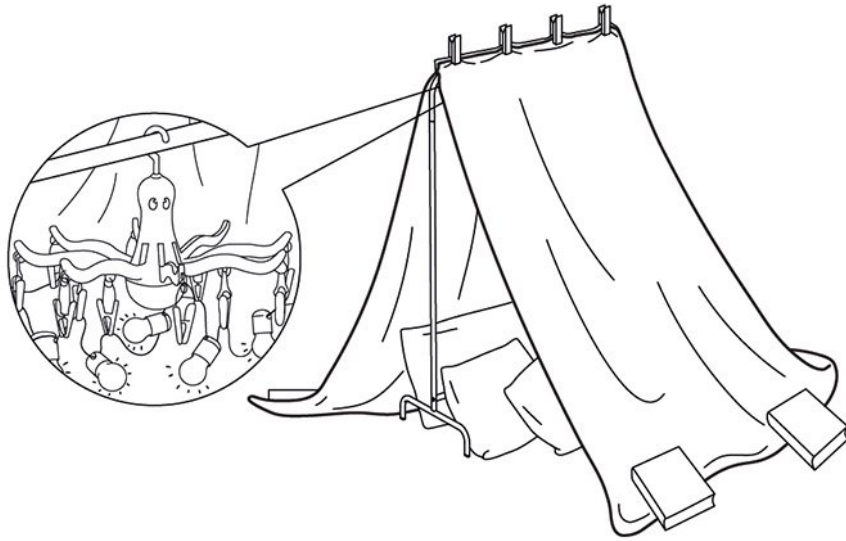

Make sure that the structure is safe. Do not leave children unattended.
The suggested examples are not official IKEA user guides for IKEA products.
If you can't find the products referred to in the instructions, use similar ones.

CÅVE

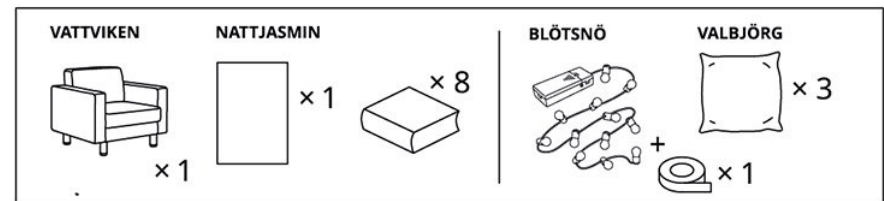
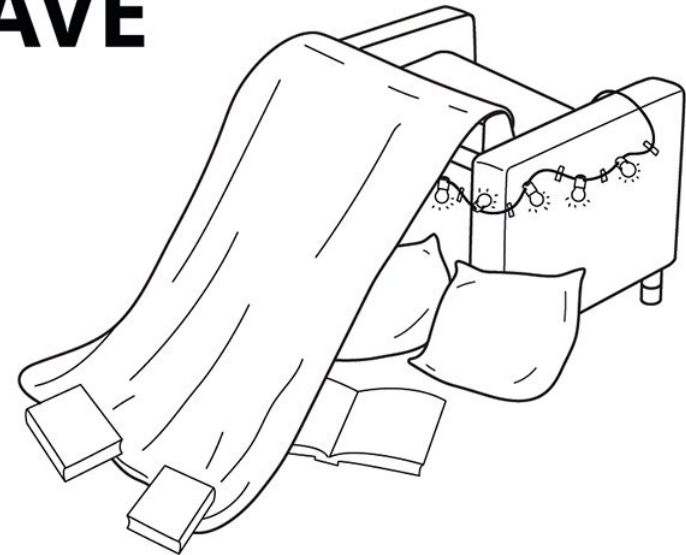

Make sure that the structure is safe. Do not leave children unattended.
The suggested examples are not official IKEA user guides for IKEA products.
If you can't find the products referred to in the instructions, use similar ones.

If you really want to get serious about building a den, check out this final website: <https://www.getoutwiththekids.co.uk/activities/making/building-a-den/>

Send us a photo of your fab new den on Seesaw



Outdoor – Scavenger Hunt

Okay, so you've made a den, right? Great.

Now your challenge is to try to collect as many of these items (below) as possible in your den. Send us a photo of what you collect on Seesaw.



Check them off when you find them to help.

AROUND THE HOUSE SCAVENGER HUNT

FIND SOMETHING:

- | | | | |
|---|--|--|--|
| <input type="checkbox"/> blue | <input type="checkbox"/> that makes a noise | <input type="checkbox"/> to read | <input type="checkbox"/> with a pattern |
| <input type="checkbox"/> with a nose | <input type="checkbox"/> green | <input type="checkbox"/> that smells | <input type="checkbox"/> that holds things |
| <input type="checkbox"/> to sit on | <input type="checkbox"/> to eat with | <input type="checkbox"/> squishy | <input type="checkbox"/> alive |
| <input type="checkbox"/> that closes | <input type="checkbox"/> white | <input type="checkbox"/> orange | <input type="checkbox"/> made of metal |
| <input type="checkbox"/> turns on and off | <input type="checkbox"/> that floats | <input type="checkbox"/> made of plastic | <input type="checkbox"/> crooked |
| <input type="checkbox"/> shiny | <input type="checkbox"/> red | <input type="checkbox"/> with wheels | <input type="checkbox"/> that opens |
| <input type="checkbox"/> round | <input type="checkbox"/> rough | <input type="checkbox"/> with paws | <input type="checkbox"/> yellow |
| <input type="checkbox"/> to write with | <input type="checkbox"/> you can see through | <input type="checkbox"/> black | <input type="checkbox"/> soft |
| <input type="checkbox"/> you can eat | <input type="checkbox"/> with eyes | <input type="checkbox"/> that lights up | <input type="checkbox"/> that sinks |
| <input type="checkbox"/> with buttons | <input type="checkbox"/> brown | <input type="checkbox"/> square | <input type="checkbox"/> tells time |
| | | <input type="checkbox"/> purple | <input type="checkbox"/> you can wear |

Outdoor – Make a crown

Using things you can find around the house or garden, let's make a crown fitting of what an amazing king or queen you are. Have a look at these instructions from the Royal Horticultural Society to help you get started.

Don't forget to show us what you make, on Seesaw.



What you'll need

A strip of card about 10cm wide, that is long enough to wrap around your head with a slight overlap

Double sided sticky tape

- Scissors

- Collecting bag

What to do

1. To make the crown cut a strip of card 10cm wide and measure it around your head to make sure that it is long enough. Put the piece of card on a flat surface and using the double sided sticky tape place a line of tape in the middle along the whole length of the card.
2. Go out into your garden or for a walk in your local park and look for lovely petals and leaves that have fallen to the ground – don't pick off the plants! Carefully put them in your collecting bag and take them home.
3. Take the top layer of the sticky tape away so that it feels sticky to touch and design and decorate your crown by placing petals and leaves on to the card. Leave a space at each end with no petals and leaves, so that you can stick the ends together when you have finished.
4. Ask a grown up to help measure the card round your head so that it fits and press the ends together. Why not have a lovely picnic in your garden wearing your summer crowns?



School Games Active Championships

Developed by Hull Active Schools (HAS), the School Games Active Championships are a fun, engaging, national activity campaign for children across the UK to keep active. Parents can download the TopYa! App and sign up with our school's unique code: **28281**.

Children can practise the free active challenges, submit their best performance video and receive free personal coaching feedback from the experienced virtual coaches. For each video submitted, children can earn points, climb the leaderboard and even win prizes.

Parents, check out this video tutorial for more information:

<https://vimeo.com/423604569>